



280X280X80mm



General Specifications

Housing	Aluminum
Impeller	Steel
Motor Type	AC Induction Capacitor
Connecting	Terminal
Safety	Thermally Protected (Auto Restar)
Type of Protection	IP54

Dimensions:mm

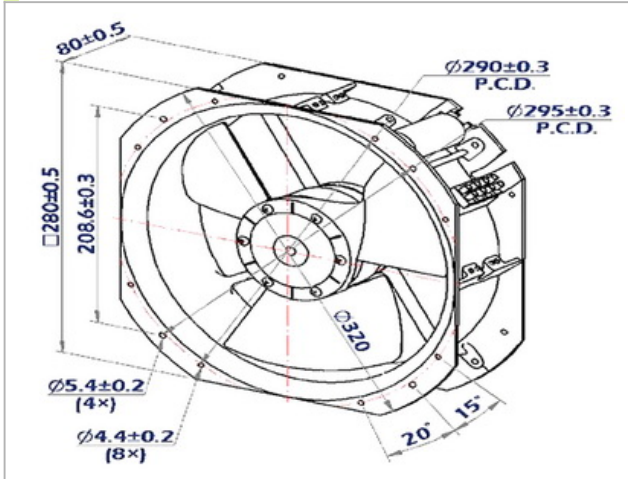

Performace

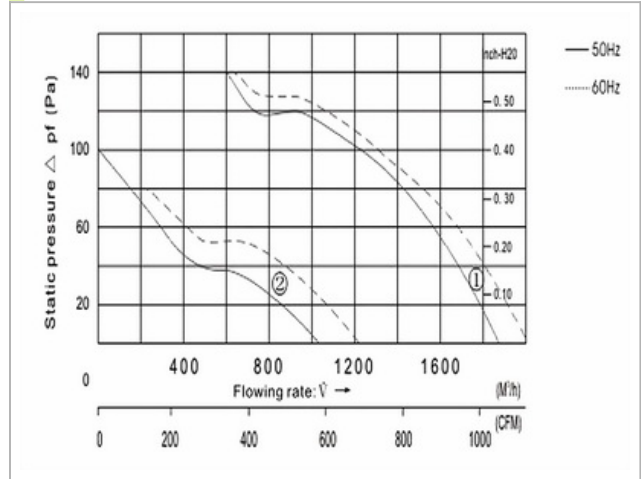

Specifications

Model NO.	Bearing	Rated Voltage VAC	Frequency HZ	Speed RPM	Airflow CFM	Static Pressure mmAq	Current A	Power W	Noise dBA
GF-B280H1-80	2BALL	110/120	50/60	2480/2600	1060/1150	24.5/20.5	0.97/1.36	110/155	68/70
GF-B280H2-80	2BALL	220/240	50/60	2500/2650	1060/1150	24.5/20.5	0.51/0.70	115/160	68/70